



**Stormwater
Management
Academy**

*"Managed stormwater is
good water."*

Final Report: Project #B236

Alternative Stormwater Sorption Media for the Control of Nutrients



Submitted by

**Marty Wanielista
Ni-Bin Chang**

**Stormwater Management Academy
University of Central Florida
Orlando, FL 32816**

September 2008

EXECUTIVE SUMMARY

High nitrogen and phosphorus quantities in stormwater runoff have the potential to impact ecosystem integrity and human health. Nitrate may be toxic and can cause human health problems such as methemoglobinemia, liver damage and even cancers. Phosphorus may trigger eutrophication issues in fresh water bodies, which could result in toxic algae and endanger the source of drinking waters.

The objective of this research is to conduct material characterization of particular types of sorption media that are functionalized for nutrient removal. The term sorption media is used as a qualifier for the media because the pollutant removal is by surface bonding to the media or incorporation within the media. A sorption media which is formulated and tested for specific pollutant removal in a specific stormwater installation is designated as a functionalized sorption media. To predict the nutrient removal value, mathematical equations for nutrient removal (called Langmuir and Freundlich isotherms) are used.

Sorption media with mixes containing recycled materials, such as sawdust and tire crumb, combined with sand/silt and limestone are recommended for nutrient removal in stormwater management ponds and retention areas. The ponds are typically called retention ponds because the stormwater infiltrates into the ground and is not discharged to surface waters. Other retention areas, such as those defined as bio retention can also use the sorption media. The life time of the media based on orthophosphorus (OP) removal is calculated from the isotherms and is shown to be a reasonable application. Also, the capital cost is reasonable and there is minimal operating cost.

Pollutants of concern include ammonia, nitrite, nitrate, orthophosphate, total dissolved phosphorus, etc. Application potential in stormwater management facilities, such as dry and wet ponds, is emphasized. As compared to a natural soil that is selected as the control case in the testing, the functionalized sorption media proposed here is proved relatively more effective in terms of removing most of the target nutrient

pollutants under various conditions of influent waste loads. Column tests with unsaturated followed by saturated conditions indicate removal of nitrate. These tests were conducted under natural conditions and then under non biological conditions (abiotic). Comparing the natural to the non biological testing showed that the reactions in a short period of time are due to sorption and other physiochemical means and not to biological. It is understood however that biological removal would take place in a longer time period. A second order reaction kinetic appears to more closely represent the removals of most nutrient species. The determination of the reaction order is important to obtain the best predictive mathematical relationship for nutrient removal.

Future research should be encouraged to mix the selected media with other sorption media for both stormwater and wastewater treatment. It may also focus on the detection of microbiological activities, such as ammonia oxidizing bacteria (AOB), nitrogen oxidizing bacteria (NOB) and denitrifiers, to ensure the denitrification process is prevalent.

ACKNOWLEDGMENTS

The research team deeply appreciates and acknowledges the support of the Southwest Florida Water Management District and the professional advice and guidance of Chris Zajac from the District.

TABLE of CONTENTS

EXECUTIVE SUMMARY.....	1
ACKNOWLEDGMENTS	3
LIST OF TABLES.....	5
LIST OF FIGURES	6
INTRODUCTION	7
LITERATURE REVIEW	9
Nutrient Concentrations in Groundwater Systems in Florida.....	9
Stormwater Best Management Practices	10
Sorption Media Used for Nitrogen Species Removal.....	10
Sorption Media Used for Phosphorus Species Removal	12
APPROACH.....	18
Material Preparation and Characterization	18
Isotherm Study for the Sorption Media Mixture	20
Life Expectancy of the Sorption Media (when it no longer removes pollution)	22
Removal Efficiency, Kinetics, and Head Loss	22
Abiotic Test.....	26
RESULTS AND DISCUSSION.....	27
Material Characterization.....	27
Isotherm Study for the Sorption Media Mixture	28
Life Expectancy of the Media (does not include biological uptake)	31
Removal Efficiency	32
Kinetic Reactions.....	34
APPLICATION POTENTIAL	37
Head Loss.....	37
Engineering Feasibility Study.....	37
Cost and Benefit.....	40
CONCLUSIONS.....	43
LIST OF REFERENCES	45

LIST OF TABLES

Table 1 Sorption media used to remove nitrogen and phosphorus from stormwater or wastewater	13
Table 2 Multi-decision Criteria Matrix Example	19
Table 3 Method used to determine effluent concentration for each chemical species.....	25
Table 4 Data showing the physical properties of natural sand and sorption media.....	27
Table 5 Data showing the properties of Langmuir isotherm for different species.	29
Table 6 Data showing the properties of Freundlich isotherm for different species.....	29
Table 7 Life expectancy of sorption media mixture for different nutrient.....	32
Table 8 Summary of removal efficiency in column test	34
Table 9(a) Summary table of kinetics for the sorption media mixture	36
Table 9(b) Summary table of kinetics for the natural soil (Hunter’s Trace soil)	36
Table 10 Pond Cost Comparisons	41

LIST OF FIGURES

Figure 1 Schematic diagram of the column setup and whole system.....	24
Figure 2 Particle size distribution of natural soil (a) collected from Hunter’s Trace pond and sorption media mixture (b).....	28
Figure 3 Figure showing the isotherm study for ammonia. (a) is Langmuir isotherm plot and (b) is Freundlich isotherm plot	29
Figure 4 Figure showing the isotherm study for orthophosphate. (a) is Langmuir isotherm plot and (b) is Freundlich isotherm plot.....	30
Figure 5 Figure showing the isotherm study for nitrate. (a) is Langmuir isotherm plot and (b) is Freundlich isotherm plot	30
Figure 6 Figure showing the isotherm study for nitrite. (a) is Langmuir isotherm plot and (b) is Freundlich isotherm plot	30
Figure 7 Figure showing the isotherm study for total dissolved phosphorus. (a) is Langmuir isotherm plot and (b) is Freundlich isotherm plot	31
Figure 8 Wet pond with in-situ treatment units and low infiltration.....	39
Figure 9 Retention pond with in-situ treatment	40

INTRODUCTION

Nutrients such as ammonia, nitrate, nitrite orthophosphate and dissolved phosphorus are common contaminants in water bodies all over the world. Nutrient levels are an important consideration within the State of Florida and unquestionably within the Southwest Florida Water Management District. Nutrient removal is very important for the sustainability of the aquatic ecosystem and environment. All these nutrients have acute and chronic harmful outcomes for human beings and ecosystems directly or indirectly. According to USEPA, unionized ammonia is very toxic for many fish species (USEPA, 1993). Fish mortality, health and reproduction can be hampered by the presence of 0.100 mg/L to 10.000 mg/L of ammonia (USEPA, 1993). Nitrate is more toxic than nitrite and can cause human health problems such as liver damage and even cancers (Gabel et al., 1982; Huang et al., 1998). Nitrate can also bind with hemoglobin and create a situation of oxygen deficiency in infant's body called methemoglobinemia (i.e., a blood disorder of infants) (WEF, 2005). This disorder is also known as "blue baby" syndrome. Nitrite, however, can react with amines chemically or enzymatically to form nitrosamines that are very strong carcinogens (Sawyer et al., 2003).

Nitrogen and phosphorus compounds are the most frequent measurements to indicate nutrient loadings. Nitrogen and phosphorous-containing compounds are found in urban stormwater runoff primarily from highways (USEPA, 1999). Nitrates normally result from vehicular exhaust on the road itself and adjacent soils from fertilization of landscaped areas beside the roads and the neighboring residential areas (German, 1989; Vitousek et al., 1997). On the other hand, when urban regions gradually expand due to regional development, centralized sewage collection, treatment, and disposal is often unavailable for both geographic and economic reasons. Thus, decentralized or on-site wastewater treatment systems (OWTS) may be necessary to protect public health.

Nationwide, wastewater effluent from OWTS can represent a large fraction of nutrient loads to groundwater aquifers.

Nitrogen, particularly nitrate-N, easily moves from terrestrial ecosystems into surface and ground waters, including lakes, streams, rivers, and estuaries (Baker, 1992; Kahl et al., 1993; Peterjohn et al., 1996). According to USEPA, nitrate and nitrite levels in the water bodies should not be above 10.000 mg/L NO_3^- -N and 1.000 mg/L NO_2^- -N, respectively (USEPA, 1988). These are drinking water standards and not related to the ecology of surface waters. For effective stormwater management, bioretention or biofiltration ponds are a relatively new urban stormwater best management practice (BMP) (Hsieh and Davis, 2005). Yet the use of differing sorption media in wet and dry bioretention ponds turns out to be an appealing engineering approach in dealing with the increasing trend of higher nutrient concentrations that is expected to continue in the surface and groundwater systems. Large-scale implementation with different sorption media to remove nutrients will be popular in the future (Mothersill et al., 2000; Birch et al., 2005).

The main purpose of this research is to examine the material property, sorption capacity and reaction kinetics of selected mixes of sorption media for nutrient removal using batch and column tests. Pollutants of concern mainly include ammonia, nitrate, nitrite, and orthophosphate. Sorption media of interest include but are not limited to tire crumb, sawdust, activated carbon, iron amended resins, orange peel, peat, leaf compost, naturally occurring sands, zeolites, coconut husks, polymers, soy bean hulls, etc. The expected findings in this study are to: 1) determine the sorption isotherm for different nitrogen and phosphorus species, 2) determine the life expectancy of sorption media to be used in field, 3) estimate the removal efficiency of nutrients from stormwater, 4) understand the kinetics of sorption media mixture, and 5) decide the fate and transport of nutrient in stormwater and describe the field implementation potential.

LITERATURE REVIEW

Nutrient Concentrations in Groundwater Systems in Florida

The Upper Floridan aquifer is particularly vulnerable to impacts from land-use activities in karst/high recharge areas, where the aquifer is not confined or only thinly confined. Nitrate concentrations have increased in many Upper Floridan aquifer springs since the 1950s. Phelps (2004) reported that nitrate concentrations ranged from less than 0.020 to 12.000 mg/L, with a median of 1.200 mg/L, for 56 Upper Floridan aquifer wells sampled in Marion County during 2000-2001. It is known that nitrate concentrations have exceeded 1.000 mg/L in recent years at some springs in Lake, Marion, Orange, Seminole, and Volusia Counties according to Phelps et al. (2006) and the St. Johns River Water Management District (2008). Increasing trends in nitrate concentration have been documented in Volusia County springs, such as DeLeon and Gemini Springs (Phelps et al, 2006) and Blue Spring (SJRWMD, 2008).

Stormwater runoff is one possible source of nitrogen, among others such as septic tanks and land-based application of reclaimed wastewater or fertilizer, which can contribute to elevated nitrate and nitrite concentrations in the Upper Floridan aquifer. The Florida Department of Environmental Protection (FDEP) and St. Johns River Water Management District (SJRWMD) also did research in 1998 to determine the nutrient concentration in stormwater (Graves et al., 1998). They reported maximum total phosphorus was 0.329 mg/L, orthophosphate was 0.265 mg/L, total nitrogen was 1.300 mg/L, ammonia-nitrogen (NH₃-N) was 0.046 mg/L, and the combined nitrate-nitrogen (NO₃-N) and nitrite-nitrogen (NO₂-N) was 0.048 mg/L (Graves et al., 1998).

Stormwater Best Management Practices

A number of devices, collectively known as structural Best Management Practices (BMPs), were employed to treat contaminated stormwater with respect to either physicochemical or microbiological principles (Ray et al., 2006). Nutrient in stormwater and groundwater can be removed by using physicochemical processes, such as activated carbon adsorption, ion exchange with synthetic resins, reverse osmosis, and electro dialysis. Biofiltration processes with differing sorption media have been gaining popularity over the other physicochemical processes due to their cost-effectiveness. Within the context of biofiltration or biological plus filtration removal, two important processes that result in the transformation of nitrate are nitrification and denitrification. Nitrification is a process in which ammonium is oxidized and denitrification is a process in which nitrate is reduced back to nitrogen gas before escaping into the air. However, only denitrification as a microbiologically mediated process occurring under anaerobic (oxygen depleted) conditions can result in the permanent removal of nitrate. This deeply affects the design philosophy of stormwater biofiltration ponds. Also, sorption media may improve solid-liquid contact and prevent channeling via physicochemical processes, such as adsorption, absorption, and ion exchange. In general, higher surface area of clay in natural soil might be able to provide more contact area for the solid to adsorb and more space for bacteria to develop the colony. A sorption media which is formulated and tested for specific pollutant removal in a specific stormwater installation is called a functionalized sorption media. It might have a better ion exchange capacity to support adsorption/desorption capacity. Consequently, a comparative study for a quantitative process-based understanding of the kinetics due to stormwater impact would gain a renewed interest for promoting the biofiltration process in BMPs.

Sorption Media Used for Nitrogen Species Removal

Many researchers have tried to remove nitrogen species from stormwater runoff by using sorption media. Kim et al., (2000) used different kinds of sorption media, such as alfalfa, mulch compost, newspaper, sawdust, wheat straw, and wood chips. They found that alfalfa and newspaper had 100% nitrate removal efficiency while mulch compost had

60% nitrate removal efficiency. They also found that sawdust, wheat straw and wood chips had good removal efficiency (>95%), but wood chips showed consistently better performance in nitrate removal over sawdust. From their experiment, it could be concluded that all of these were electron donors and good carbon sources for promoting denitrification. They suggested that increasing the retention time may gain better removal efficiency. Kim et al. (2000) also found that soil could only remove 7% to 10% of nitrate due to its anionic form.

Güngör and Ünlü (2005) conducted nitrate and nitrite removal experiments by using only three types of soils, including sandy clay loam (SCL), loamy sand (LS) and sandy loam (SM). They found a high nitrate removal using all three soils (i.e., over 90%). Hsieh and Davis (2005) found that mulch was very effective in removing nitrate, unlike sand. But they had not gained good ammonia removal efficiency by using mulch. They concluded that soil with higher silt/clay and cation (Mg/Ca/K) contents might be very effective in nutrient removal. They concluded that coarse media might not be able to retain the nutrient in repetitive loading due to small surface area so that sand should not be used.

Darbi et al., (2002) used sulfur and limestone for nitrate removal from potable water. In their experiment, sulfur was used as an electron donor and limestone was used to maintain the pH. They found that the optimum mixing ratio of sulfur and limestone is 1:1 for nitrate removal (i.e., about 98% nitrate removal was observed). They also suggested that increasing the retention time may obtain higher nitrate removal efficiency. Lisi et al. (2004) tried to use granulated tire for the removal of nitrate. They found 48 g of tire crumb can remove 16.2 g of NO_3^- -N. Sengupta and Ergas (2006) did an experiment to remove nitrate from wastewater by using marble chips, limestone and oyster shell. Their experiment gave some significant outcomes when using those solids as sorption media. They found that oyster shell (almost 98% CaCO_3) and limestone could remove 80% and 56% of nitrate, respectively. The pH and alkalinity were higher in testing using oyster shell rather than limestone and marble chips. Oyster shell was very efficient to reduce nitrite accumulation and dissolved oxygen (DO) did not work as a denitrification inhibitor when oyster shell was used as a sorption media. From these findings, it can be concluded that oyster shell is much more effective than limestone or marble chips for

removing nitrate. Oyster shell can also be a good candidate for controlling the pH that is sensitive for denitrification.

Savage and Tyrrel (2005) used a mix of wood mulch, compost, soil, broken brick and polystyrene packaging for removal of $\text{NH}_3\text{-N}$ from compost leachate. They reached a conclusion that a blend of wood mulch and compost had better removal efficiency for $\text{NH}_3\text{-N}$ than other media and polystyrene was the least capable in removing $\text{NH}_3\text{-N}$. Soil and broken brick could remove 38% and 35% of $\text{NH}_3\text{-N}$, respectively. All these media had the same capability to remove BOD_5 by microbial oxidation process. The research group found that compost and wood mulch had a tendency to increase the pH. They concluded that specific surface area, void space, permeability, and adsorption capacity might influence the removal efficiency.

Sorption Media Used for Phosphorus Species Removal

Phosphorus removal from stormwater involves both precipitation and adsorption processes due to chemical reaction. As phosphorus has a significant effect on aquatic ecosystems, researchers have been trying to discover an economically feasible removal procedure. Some functionalized sorption media that can be used for phosphorus removal are sand rich with Fe, Ca or Mg, gravel, limestone, shale, light weight aggregates (LWA), zeolite (natural mineral or artificially produced aluminosilicates), pelleted clay (along or in combination with soils), opaka (a siliceous sedimentary rock), pumice (natural porous mineral), wollastonite (a calcium metasilicate), fly ash, blast furnace slag (BFGS – a porous non-metallic co-product in iron industry), alum, goethite (a hydrous ferric oxide), hematite (a mineral form of iron(III) oxide), dolomite and calcite (Korkusuz, 2007). Table 1 summarizes all the sorption media used by different researchers to remove nutrients (both nitrogen and phosphorus species) from stormwater and wastewater (Chang et al., 2008).

DeBusk et al. (1997) used sand (with quartz), fresh organic (peat) soil, crushed lime rock (2.5 cm nominal size) and wollastonite (a mine containing calcium metasilicate plus ferrous metasilicate) to remove phosphorus (P), nickel (Ni) and cadmium (Cd) from stormwater. They found that wollastonite had very good removal efficiency for their targeted contaminants. Wollastonite could remove about 87.8% P, 97.7% Cd and 80.3%

Ni. On the other hand, limerock, peat and sand could remove 41.4%, 44%, and 41.4% P respectively. It can be concluded that wollastonite is very effective in phosphorus removal because it contains calcium and ferrous ions. Calcium and ferrous ions can remove phosphorus by precipitation reaction or adsorption.

Hsieh and Davis (2005) found good TP removal (about 41% to 48%) by sand and concluded that it might happen due to simple adsorption or complex sorption/precipitation processes. They found that mulch was not a good candidate for total phosphorus (TP) removal. This research group concluded that TP removal was highly variable and it might be related to properties of sorption media used and flow patterns of nutrient laden water through the sorption media. Again, organic matter could also accelerate TP removal up to 93%.

Richman (1997) found that compost had good removal efficiency for 90% solids, 85% oil and greases and 90% heavy metals. Clark and Pitt (2001) tried to remove contaminants in aerobic and anaerobic conditions from stormwater runoff by using activated carbon, peat moss, compost and sand. They found good phosphorus removal efficiency by all four media in both conditions. They also found no desorption condition in their system for phosphorus. But they observed that sorption was better and leaching was lesser in aerobic conditions for compost. Forbes et al. (2005) used lightweight expanded shale and masonry sand for the removal of phosphorus. They summarized that sand is a poor candidate for retaining phosphorus and expanded shale has greater removal efficiency due to its larger surface area.

Table 1 Sorption media used to remove nitrogen and phosphorus from stormwater or wastewater

No.	Sorption media	Additional environmental benefits	Physical/Chemical Properties	References
1	Alfalfa		D<4mm	Kim et al.(2000)
2	Leaf mulch compost/Mulch/ Wood compost		Silver maple, Norway maple, Red oak and Cherry mulch, size 4760 micron,	Ray et al. (2006)
			D<2mm	Kim et al.(2000)

		Oil & greases, heavy metals,	Maple & elm leaf compost	Richman (1997)
		Lead		Hsieh & Davis (2005)
3	Newspaper		D (average)<4mm, Cellulose	Kim et al.(2000)
			0.4 cm width ribbons, (25.49% extractives, 43.11% cellulose, 29.59% lignin, 2.59% ash), Cellulose	Volokite et al. (1996)
4	Sawdust		Wall structure, Monterey pine (Pinus Radiata D. Don) sawdust,	Schipper et al. (2005)
			Medium density fiberboard sawdust, Density 950 to 990 kg/m ³ , Particle size 150 to 850 micron,	Gan et al. (2004)
			D<2mm	Kim et al.(2000)
5	Wheat straw			Tshabalala (2002) Rocca et al. (2005)
			D<4mm	Kim et al.(2000)
6	Wood chips/Wood fibers		D = 4.0 mm	Seelsaen et al. (2006)
			D<2mm	Kim et al.(2000)
		Polynuclear Aromatic Hydrocarbons	Aspen wood fibers composed of 51% cellulose, 26% hemicellulose, 21% lignin, and 1% ash	Boving and Zhang (2002)
				Jokela et al. (2002), Savage and Tyrrel (2005)
7	Sulfur		Large particles 2 to 2.36 mm and small particles 0.6 to 1.18 mm	Kim et al.(2000),
			D =2.38 to 4.76 mm	Darbi et al. (2002),
8	Sandy clay loam (SCL)		Sand (53.28%), Silt (24.0%), Clay (22.72%)	Güngör and Ünlü (2005)

9	Loamy sand (LS)		Sand (78.28%), Silt (10.64%), Clay (11.08%)	Güngör and Ünlü (2005)
10	Sandy loam (SL)		Sand (70.28%), Silt (14.64%), Clay (15.08%)	Güngör and Ünlü (2005)
11	Limestone		with sulfur, D= 2.38 to 4.76 mm	Zhang (2002)
			D =2.38 to 4.76 mm	Darbi et al. (2002), Sengupta and Ergas (2006)
			D= 0.6 to 1.18 mm	Kim et al. (2000)
12	Oyster shell		Powder form, 28% Calcium, Average particle size 200 micron, Surface area 237 m ² /g,	Namasivayam et al. (2005)
				Sengupta and Ergas (2006)
13	Marble chips		Mg(OH) ₂ and CaCO ₃	Sengupta and Ergas (2006)
14	Peat	Cu, Zn, Ni, PAHs (Polyaromatic hydrocarbons)		DeBusk et al. (1997), Clark and Pitt (1999), Clark et al. (2001), Kietlińska and Renman (2005)
15	Activated carbon	Cu, Fe, Pb, Zn		Clark et al. (2001)
16	Carbon sand, enretech sand or sand			Bell et al. (1995), DeBusk et al. (1997), Clark and Pitt (1999), Clark et al. (2001), Seelsaen et al. (2006)
17	Tire crumb	2,4-dichlorophenol (DCP), 4-chlorophenol (CP)	20 to 40 mm,	Shin et al. (1999)
		Volatile organic carbon		Lisi et al. (2004)

18	Zeolites	Benzene, Sulfate, Chromate		Clark and Pitt (1999), Li (2003), Seelsaen et al. (2006)
19	Cotton waste		Cellulose	Rocca et al. (2005),
20	Perlite			Redco II (2007)
21	Clay	Thiocyanates, Cadmium, Lead, Nickel		Harris et al. (1996), Gálvez et al. (2003), Lazaridis (2003)
22	Zeolite+ Clay			Gisvold et al. (2000)
23	Expanded shale and masonry sand		Expanded shale (SiO ₂ 62.06%, Al ₂ O ₃ 15.86%, Fe ₂ O ₃ 5.80%, CaO 1.44%, MgO 1.68%)	Forbes et al. (2005)
24	Opoka			Braun-Howland (2003)
25	Wollastonite		a mine containing calcium metasilicate plus ferrous metasilicate	DeBusk et al. (1997) Hedström (2006)
26	Iron Sulfide			Tesoriero et al. (2000), Baeseman et al. (2006)
27	Limerock		2.5 cm nominal size	DeBusk et al. (1997)
28	Polyurethane porous media		Porous structure, Average diameter 3-5 mm, External pore diameter 300 micron.	Han et al. (2001)
				Hedström (2006)
29	Blast furnace slag	Zn, Ni, Co, Cu, Ba,	SiO ₂ 36.2%, CaO 35%, MgO 13.4%, Al ₂ O ₃ 10.6%,	Kietlińska and Renman (2005)
30	Allophane		Clay-sized mineral containing silica, alumina and water	AEC (2007)

31	Chitin		A natural polymer, technically known as polyacetylglucosamine	AEC (2007)
32	Pumice		A light, porous volcanic rock composed of iron (18.2 %), aluminum (13.7%), calcium (12.7%) and magnesium (7.3%) and other.	AEC (2007)
33	Bentonite		Montmorillonite mineral with about 4%-8% calcium carbonate,	AEC (2007)
34	Clinoptilolite			Hedström (2006)
35	Oversized pulverized brick			Savage and Tyrrel (2005)
36	Polystyrene packing			Savage and Tyrrel (2005)
37	Polonite	Zn, Ni, Co, Ti, Cu, Ba,	Manufactured from cretaceous rock Opoka (SiO ₂ 39.4%, CaO 42%, Al ₂ O ₃ 4.3%, Fe ₂ O ₃ 2.0%)	Kietlińska and Renman (2005),
38	Glass		D= 4.0 mm	Seelsaen et al. (2006)
39	Waste foundry sand	TCE, Zn, Metolachlor, Alachlor,		Benson (2001)
40	Lignocelluloses material		Basically pine bark chips,	Tshabalala (2002)

APPROACH

Material Preparation and Characterization

Additional laboratory evaluation for nutrient removal is necessary to further document removal potential and design properties of each media or a mix of media. It is very important to understand the physical properties (i.e. density, void ratio, porosity, specific gravity, surface area and conductivity) of the sorption media available for Florida use and to document in a laboratory these properties. These properties are used to determine the hydraulic residence time and adsorption area available. These properties with other criteria are used to screen the possible sorption media before laboratory studies. The five criteria for screening are: 1) the relevance of nitrification or denitrification process or both with documented literature effectiveness, 2) the hydraulic permeability or permeability, 3) the cost, 4) the availability in Florida, and 5) additional environmental benefits. All of these criteria were equally weighted and a qualitative assessment of each was made. The qualitative assessment was then converted to a numerical value. An example of some of the media assessments are shown in Table 2, and illustrates the procedure, assumptions and depth of review in a multi-decision matrix. All of the media were assessed in the same manner. The process is subjective in nature, but is an attempt to quantitatively decide on the media that can be investigated further. Not all media could be investigated further to document potential nutrient removal because of budget constraints. Initial thinking was to eliminate all non-Florida available media. However, it was decided not to limit the selection to Florida based materials alone because of the potential for eliminating a cost effective solution.

Seven sorption media were selected for final consideration according to a multi-criteria decision making process. They include peat, sandy loam, sawdust, wood chip, tire crumb, crushed limestone, and crusted oyster. A mix of these is considered for final selection and for physical laboratory analyses, kinetic estimates, and isotherm studies. Newspaper was eliminated from additional considerations when it was found to contain toxic ink and its toxicity could not be determined from the literature. Compost was also eliminated when the consistency of materials could not be documented.

Table 2 Multi-decision Criteria Matrix Example

No.	Sorptions Media	Criteria 1		Criteria 2	Criteria 3	Criteria 4	Criteria 5	Overall *
		1a	1b					
1.	Florida Peat	5	5	5	5	5	5	5
2.	Alfalfa	3	3	1	1	0	5	2
3.	Activated carbon	5	1	1	1	0	5	2
4.	Carbon sand	5	1	1	1	0	5	2
5	Sandy Loam (SL), Loamy Sand (LS), and Sandy Clay Loam (SCL), Planting soil	5	5	3	5	5	5	4.6
6.	Sawdust (untreated wood)	3	5	3	5	5	5	4.4
7.	Lignocellulosic Materials/wheat straw	3	3	1	1	0	5	2
8	Tire Crumb	4	5	3	3	5	5	4.1
9.	Crushed Limestone	2	5	1	5	5	5	4.9
10.	Crushed oyster	2	5	1	5	5	5	4.9
11.	Wood chips	3	4	1	5	5	5	4.9
12.	Zeolites	4	3	1	1	0	5	2.1

Criteria matrix: 1. Relevance and literature based removal effectiveness, 2. permeability, 3. cost, 4. availability in Florida, 5. additional environmental benefits

1a. phosphorous (unsaturated and saturated)

1b. Nitrogen saturated

Quantitative evaluation (qualitative evaluation)

Criteria 1: 5 (excellent), 4 (very good), 3 (good), 2 (Fair), 1 (Poor)

Criteria 2 and 3: 1(Low), 3 (Medium), 5 (High)

Criteria 4 and 5: 5 (Yes) or 0 (No)

* Overall is calculated as weighted average based on equal weight among five criteria

NOTE. **Bold** lettering designates those media used to quantify removal.

Both tire crumb and sawdust are lighter than water. Tire regeneration from scrap tire is not economically possible due to the process of making rubber for tires (Lisi et al., 2004). Blrkholz et al. (2003) did toxicological testing on tire crumb and found that no

DNA and chromosome damaging chemicals are present due to the use of tire crumb in the environment. Wanielista (2008) also showed a very high LC50 value or basically no acute toxicity for tire crumb. Hence, the inclusion of tire crumb and sawdust is viewed as part of the resources recovery with sustainable implication in this study. Limestone was crushed by Universal Testing Machine (UTM) and particle size was about 250 microns. A mix of citrus grove sand, tire crumb, saw dust, and limestone are used as the proposed sorption media. The natural soil was collected from a dry pond (Hunter's Trace) in Marion County, Florida and used as a control in the column test. This soil showed significant difference in hydraulic conductivity in both wet and dry condition. For this reason, physical properties of both wet and dry natural soil were determined.

The ASTM procedures were followed to determine the properties of sorption media. The specific gravity was determined by following the standard test method for specific gravity of soils (ASTM, D854-92). The procedure follows the Method A (Procedure for oven dry specimen). The pycnometer was a volumetric flask having a capacity of 500 mL and 100 g of sample was taken for the experiment. The specific gravity was measured using the ASTM D-854-92 Standard Test Method for Specific Gravity of Soils. The measured volume of the media was 100 g. The pycnometer was a volumetric flask having the capacity of 1,000 mL. The permeability test was conducted by following the standard test method for permeability of granular soils (Constant head) (ASTM, D2434-68). Several trials were run and averaged. The permeability was converted to a test temperature of water at 20°C. The particle size was determined by following the standard practice for dry preparation of soil samples for particle size analysis and determination of soil constants (ASTM, D421-85). The sample size was 1,000 g for this analysis. The surface area of sorption media mixture was determined by using Multipoint BET with nitrogen adsorption (Vacuum volumetric method) conducted by the Quantachrome Instruments, Boynton Beach, Florida. About 20 g of sample was used to determine the surface area of the proposed sorption media mixture (Moberg, 2008).

Isotherm Study for the Sorption Media Mixture

In absorption processes, pollutants in one form have a tendency to concentrate on the surface of a sorption media. In general, pollutants in liquid phase would condense on the solid surface of sorption media. Isotherms are used to predict the removal by exposing a known quantity of pollutant to various quantities of media and at a constant temperature. The isotherm gives a predictive equation that indicates when a certain amount of pollutant reaches the maximum removal for a fixed mass of media. The term isotherm also indicates that the test needs to be performed at a given temperature (Crittenden et al., 2005).

Ammonia nitrogen ($\text{NH}_3\text{-N}$) solution was prepared from anhydrous NH_4Cl from Fisher Scientific (dried at 100°C), nitrate ($\text{NO}_3\text{-N}$) solution was prepared from KNO_3 from Fisher Scientific (dried at 105°C for 24 hours) and nitrite ($\text{NO}_2\text{-N}$) solution was prepared from NaNO_2 from Fisher Scientific. Each time the solutions were freshly prepared to avoid possible contamination. Sometimes ammonia (100 mg/L) and nitrate (10 mg/L) stock solutions were purchased commercially from HACH (Loveland, CO). Standard phosphorus solution (50 mg/L) was purchased commercially from HACH.

In this experiment, about 800 g sorption media mixture was prepared by using 50% sand (400 g), 20% limestone (160 g), 15% sawdust (120 g) and 15% tire crumb (120 g). A known concentration of pollutant solution (i.e. 1 mg/L) was prepared from stock solution. 300mL of that solution was transferred into each Erlenmeyer flask and five flasks were used in this experiment. Now 50 g of sorption media mixture was placed in flask one, 100 g in flask two, 150 g in flask three, 200 g in flask four, and 250 g in flask five simultaneously. The top of the each flask was covered by parafilm so that it will be free from outside disturbance during the waiting period. All the flasks were kept on a shacking platform (Innova 2000, New Brunswick Scientific) with 50 rpm for a certain amount of time (time varies for different pollutant removal). When the waiting time had expired, the flasks were removed from shacking platform and samples were collected from the flask. The test temperature was in between 22°C and 23°C (i.e. in room temperature). Isotherm curves for ammonia, nitrate, nitrite, orthophosphate (OP), total dissolved phosphorus (TDP) were created via this procedure.

The Freundlich and Langmuir isotherms, which are commonly accepted methods, were used to draw the isotherm curves. The Langmuir isotherm assumes that each side of

the media can bind a molecule of pollutant. The Langmuir isotherm is determined by plotting a graph between $1/q$ and $1/C$, in which q is media and C is aqueous concentration of pollutant. The Freundlich isotherm is based on an empirical equation, however. It can be determined by plotting a graph between $\log q$ and $\log C$. Overall, the following two equations were applied in this study.

- Freundlich isotherm equation is (Sawyer et al., 2003),

$$\log q = \log K + \frac{1}{n} \log C \quad (1)$$

- Langmuir isotherm equation is (Sawyer et al., 2003),

$$\frac{1}{q} = \frac{1}{q_m K_{ads}} \left(\frac{1}{C} \right) + \frac{1}{q_m} \quad (2)$$

where,

q = Sorbed concentration (mass pollutant/mass sorption media)

q_m = Maximum capacity of media for pollutant (mass pollutant/mass media)

C = Aqueous concentration of pollutant (mass/volume)

K_{ads} = Measure of affinity of pollutant for the media

K = Measure of the capacity of the media

Life Expectancy of the Sorption Media (when it no longer removes pollution)

With the isotherm testing, the life expectancy of the sorption media in BMP operation can be estimated. This life expectancy can be estimated with respect to each type of pollutant of concern in the study. The maximum capacity of sorption media for a particular type of pollutant may be retrieved from the corresponding isotherm plot. The life expectancy of sorption media depends on amount of sorption media used in a specific system, concentration of nutrient in stormwater and flow rate of stormwater. If the inlet concentration of nutrient is known with the flow rate of stormwater, the amount of nutrient per year in the stormwater can be calculated, and then the life expectancy of sorption media may be easily calculated.

Removal Efficiency, Kinetics, and Head Loss

A laboratory column test method is a physical model, or microcosm, which attempts to simulate, on a small scale, a portion of the real world subsurface environment under a

controlled set of experimental conditions. Five columns were prepared in a laboratory to do the experiment. The plexiglas columns were purchased commercially from an outside vendor with a diameter of 5 cm (2 inch) and length of 30 cm (1 foot). All five columns were tied by rope with a wooden frame built in the laboratory. All joints of the columns are leak proof by using pipe thread sealant (Rectorsell 5 and Plumbing Amazing Goop). The top and bottom of the column were closed. There is a removable screw cap system to add media from the top and remove the media from the bottom of the column. A filter with glass beads (diameter of 4 mm) was placed at the bottom of the column to prevent the outward flow of finer particles from the column during the collection of samples. Although the column is 30 cm long, the media was filled up to about 22.5 cm (9 inch) from the bottom. Tygon (Saint-Gobain, no. 16) tubes are added to both the top and bottom of the column for the flow of influent to the column and effluent from the column. Influent is added to the column from a reservoir by using a peristaltic pump (Master flex L/S, Cole-Parmer instrument). Overall, seven parameters were used to assess the scenarios in five columns to address the process design issues.

Kinetics is a study that focuses on how fast the anticipated reaction may happen. It is not equivalent to removal efficiency but it is an engineering parameter that is critical to the size of reactor required to accommodate such a chemical or biological reaction. In this study, the spectrum of chemicals of concern in kinetics include ammonia, nitrate, nitrite, total nitrogen, orthophosphate, total phosphorus, and total dissolved phosphorus and such a parameter (i.e., size of reactor) can be derived from our column study. To explore the dynamics of a system, kinetics may be derived for each species with different influent concentrations that mimic the actual fluctuations in stormwater ponds. The ultimate design of the size of a reactor, however, has to be tied with a conservative option among all pollutants of interest so as to guarantee a reliable treatment across all pollutants.

A schematic diagram of the column setup is given in Figure 1. Four columns were loaded with same media (580 g of media mixture), and the fifth column was loaded with natural soil collected from the Hunter's Trace pond in Marion County, Florida, which was used as the control case. The reason for such separation of testing in different columns with respect to different chemical species is to avoid the cross contamination by

different chemical species of interest. The surface area of sorption media might play an important role for the ion exchange, adsorption, absorption, and the growth of microbes for nitrification/denitrification. It is expected that sorption processes may dominate the system in the first few hours that allows us to retrieve the kinetics information solely.

No pretreatment of the sorption media and natural soil was done because those pretreatments cannot be applicable in practical situations. The stormwater was collected from the UCF campus. The influent concentration of the stormwater was then controlled by spiking from stock solution (i.e., augmentation). The influent concentration portfolio for all testing species is comprised of 5 mg/L, 2.5 mg/L and 0.5 mg/L although it might vary by $\pm 5.0\%$ in actual testing due to the instability of augmentation. The experiment was done in a batch mode and about 250 mL of sample was used for measurement in each batch test. The five columns were flushed three times upfront by the same solution so as to avoid the influence of prior contamination in the testing materials. When the flushing had finished, the valve at the bottom of each column was closed to retain the nutrient laden solution in the media. The samples were collected after 1 hour, 3 hours and 5 hours generally by opening the valve at the bottom except for ammonia and total nitrogen. For ammonia and total nitrogen, the sample collection time was 0.5 hour, 1.0 hour and 1.5 hours. Each time, about 60 mL sample was collected from each column for the kinetics study. The samples were diluted in case of higher concentration during the chemical analysis.

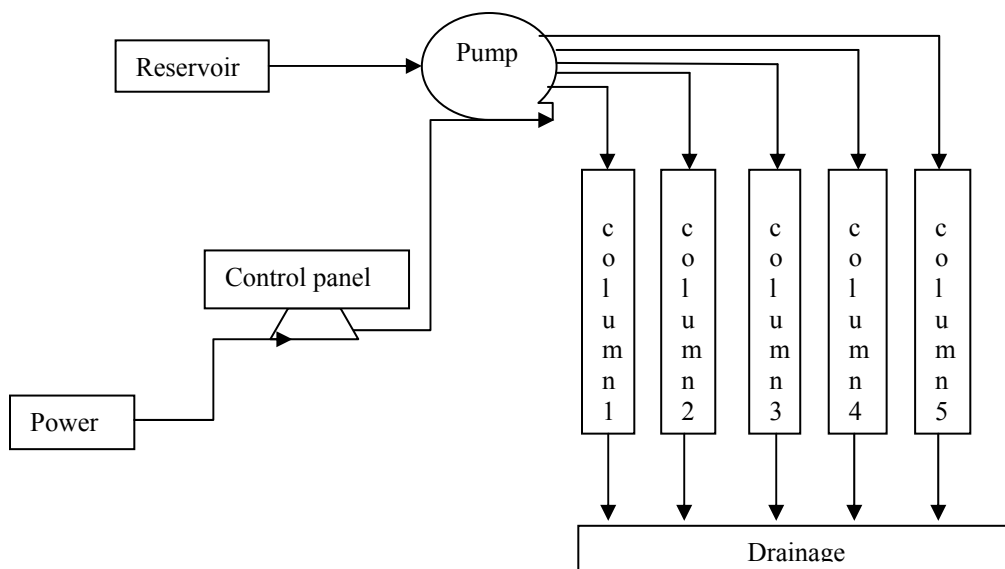

Figure 1 Schematic diagram of the column setup and whole system

A list of methods used in the chemical analysis is shown in Table 3. HACH method was used to determine the effluent concentration of ammonia, nitrate and orthophosphate. A HACH 2800 spectrophotometer is used to determine the effluent concentration. Powder pillows (purchased from HACH Company, Loveland, CO) were used for the experiment. The pH values were measured by using an Accumet research meter (AR 50-duel channel pH meter). In these columns, however, nitrification/denitrification and sorption mechanism may work together in the removal process.

Table 3 Method used to determine effluent concentration for each chemical species

Chemical Species	Title of Method	Method No.
Ammonia as nitrogen	Salicylate method	Method 8155
Nitrate as nitrogen	Cadmium reduction method	Method 8192, 8171
Nitrite as nitrogen	Diazotization method	Method 8507
Total nitrogen	Persulfate digestion method	Method 10071
Total dissolved phosphorus	Acid persulfate digestion method	Method 8190
Total phosphorus	Acid persulfate digestion method	Method 8190
Orthophosphate	PhosVer 3 (Ascorbic acid) method	Method 8048

Kinetic studies have a significant role for the design of a proper reactor to produce the desired product. In most studies, it is common to first assume reaction order as a first-order (see Equation 3a), and rate constant k (hr^{-1}) is calculated from the slope of the line for $\ln[C_0/C]$ vs. reaction time. Integration of equation results in

$$-dC/dt = k [C] \quad \ln [C_0/C] = kt \quad (3a)$$

where, C_0 is the influent concentration of dissolved contaminant (i.e., nutrient pollutant).

Rates of the reaction orders may be calculated from liner regression of $\ln[C_0/C]$ vs. reaction time for the reduction of ammonia, nitrite, nitrate, orthophosphate, etc. if the first-order kinetics works well. If first-order reaction is not a good fit, a second-order reaction may be assumed as the kinetics by a similar approach in which graphs between $1/C$ vs. time for each species may be plotted for identification (see Equation 3b).

$$-dC/dt = k [C][H^+] \quad 1/[C] = 1/[C_0] + kt \quad (3b)$$

The head loss of the column, which is something to do with permeability or percolation rate indirectly, was also measured to provide us with the information related to the flow regime. Two new columns with the same size as the column tests were built in the laboratory. Each column has three holes: one is at the top, one is at the bottom and one is at the middle. The distance between top and bottom holes is about 22.86 cm and the middle hole is about 11.43 cm below the top one. A tube with an inner diameter of 5 cm was connected with each hole by glue as a piezometric tube. The water was directed to flow continuously into the column from a reservoir that is about 120 cm above the datum line (Floor of the room is considered the datum line and column bottom is about 10.16 cm above the floor). The reading of head loss was taken after 15 minutes of the water flow.

Abiotic Test

An abiotic column test is one without living organisms. It is believed that the primary mechanism for nutrient removal is non biological in the short time column test, but this must be proven. It is a major concern during the experiments as to whether the removal process of nutrients from stormwater is due to either the physicochemical or microbiological process. An abiotic test is conducted to confirm the removal process. A stock solution of 2000 mg/L of $HgCl_2$ was prepared for abiotic control. Nine ml of $HgCl_2$ was added into every liter of influent. The retention time was 5 hours for nitrate and OP and 1 hour for ammonia, respectively. The abiotic test was conducted for ammonia in response to the presence of the nitrifier organisms, whereas the testing is conducted for nitrate and phosphorus in response to the presence of denitrifiers and Phosphorus Accumulating Bacteria (PAB), respectively.

RESULTS AND DISCUSSION

Material Characterization

Table 4 shows the physical properties of natural soil and sorption media mix used in the experiment. Sorption media proposed in this study has larger porosity and void ratio than natural soil at Hunter’s Trace pond. The soil packed into the columns cannot be oven dried, so the permeability was also tested using a moist sample. The permeability of the moist sample of Hunter’s Trace soil and sorption media were measured to be 4.470 cm/hr (1.759 in/hr) and 3.580 cm/hr (1.410 in/hr), respectively. The Hunter’s Trace soil contains clay particles that are small, therefore a larger surface area was observed. The sorption media is composed of larger particles, like saw dust and tire crumb, thus making the surface area smaller than that of Hunter Trace soil.

Table 4 Data showing the physical properties of natural sand and sorption media.

	Hunter’s Trace (dry sample)	Hunter’s Trace (moist sample)	Sorption media mix
Dry density (g/cm ³)	1.560	1.730	1.210
Void Ratio	0.670	0.510	0.740
Porosity	0.400	0.340	0.420
Specific Gravity (Gs)	2.620	2.620	2.110
Surface Area (m ² /g)	-	-	0.604
Intrinsic Permeability (cm/hr)	62.480	4.470	3.580

To determine the particle-size distribution a sieve analysis was performed. Figures 2(a) and 2(b) present the gradation curves of natural soil at Hunter’s Trace site and sorption media comparatively. The Hunter’s Trace pond soil had a larger fraction retained on various sieve sizes as compared to the others. For example, approximately 91% was retained on the 100 U.S. Standard size sieve for the Hunter’s Trace location whereas only approximately 75% was retained for the media mix proposed. The particle-size distribution of media mix is well graded. Size characteristics of both natural soil and sorption media, such as effective size and uniformity factor, reveal some features that are related to the kinetics, absorption capacity, homogeneity, and permeability that collectively form the system function. For example, the effective sizes of natural soil and

sorption media are 0.165 mm and 0.150 mm, respectively; and it implies that the effective pore-spaces within the soil architecture are relatively smaller than that of the sorption media. It therefore implies that sorption media may have lower filter media hydraulic resistance effect.

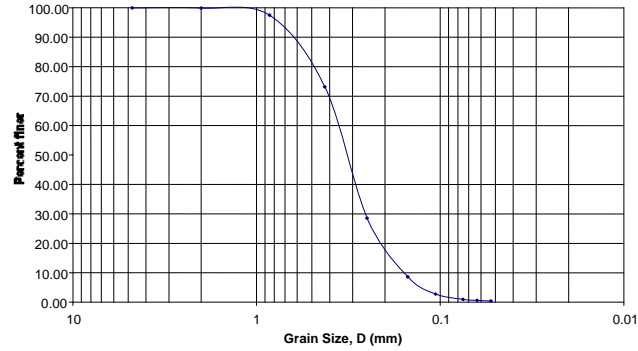

(a)

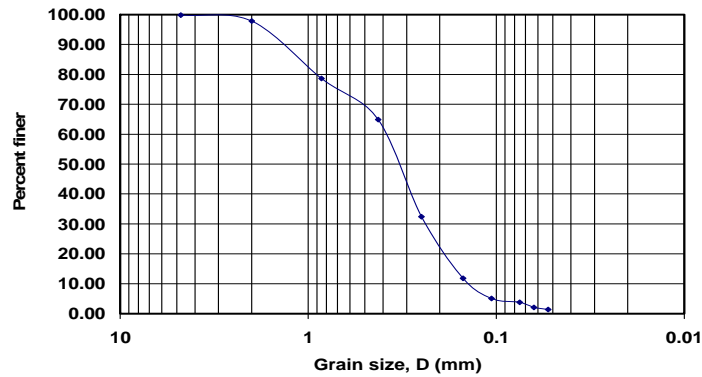

(b)

Figure 2 Particle size distribution of natural soil (a) collected from Hunter’s Trace pond and sorption media mixture (b)

Isotherm Study for the Sorption Media Mixture

From Table 6, it is observed that the value of n is above 1 for nitrate and TDP. When the n=1 or less, it indicates that all cases of media have equal affinity for the pollutant. For greater removal, the value of n should be less than one. When n>1, it means affinity decreases with increasing adsorption density (Sawyer et al., 2003). The value of

maximum capacity of pollutant for sorption media is also shown by q_m . The isotherm graphs (Figures 3-7) are shown below to illustrate the results of the analyses.

Table 5 Data showing the properties of Langmuir isotherm for different species.

Species	Isotherm equation for Langmuir	R-square value	$1/(q_m K_{ads})$	$q_m K_{ads}$	$1/q_m$ in mg/mg	q_m in mg/mg
NH ₃ -N	$y=10233x-8880.7$	0.941	10233	0.000	-8880.7	-0.000
OP	$y=272.85x-129.74$	0.970	272.85	0.004	-129.74	-0.008
NO ₃ -N	$y=128.74x+1030$	0.801	128.74	0.008	1030	0.001
NO ₂ -N	$y=229620x-229133$	0.844	229620	0.000	-229133	-0.000
TDP	$y=101.12x+137$	0.741	101.12	0.010	137	0.007

Note: $y=1/q$ and $x=1/C$

Table 6 Data showing the properties of Freundlich isotherm for different species.

Species	Isotherm equation for Freundlich	R-square value	$1/n$	n	LogK	K in mg/mg
NH ₃ -N	$y=3.951x-3.213$	0.951	3.951	0.253	-3.213	0.001
OP	$y=1.293x-2.215$	0.955	1.293	0.774	-2.215	0.006
NO ₃ -N	$y=0.231x-3.043$	0.847	0.231	4.331	-3.043	0.001
NO ₂ -N	$y=34.571x-3.389$	0.754	34.571	0.029	-3.389	0.000
TDP	$y=0.771x-2.268$	0.747	0.771	1.298	-2.268	0.005

Note: $y=\log q$ and $x=\log C$

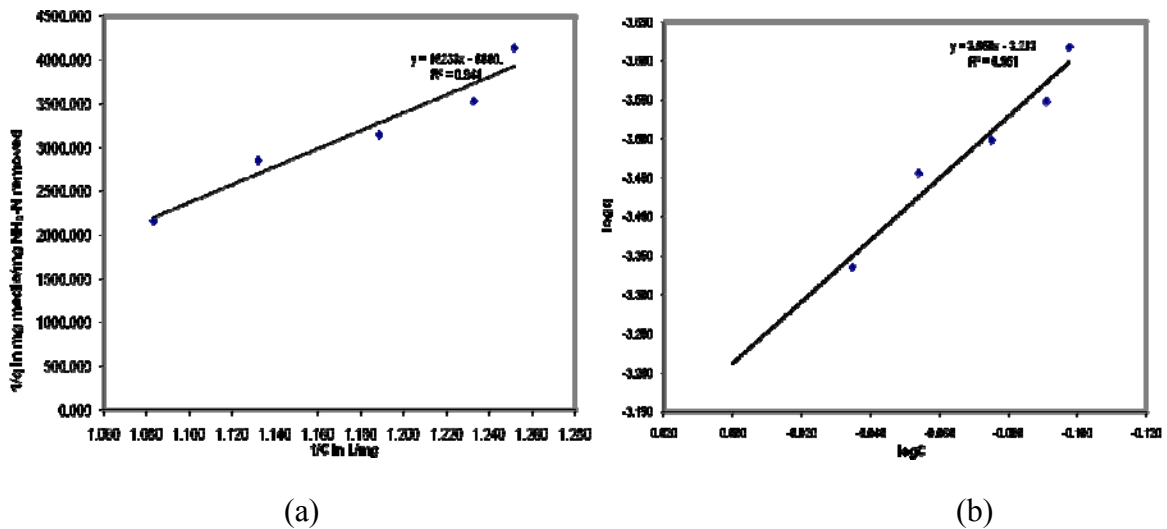
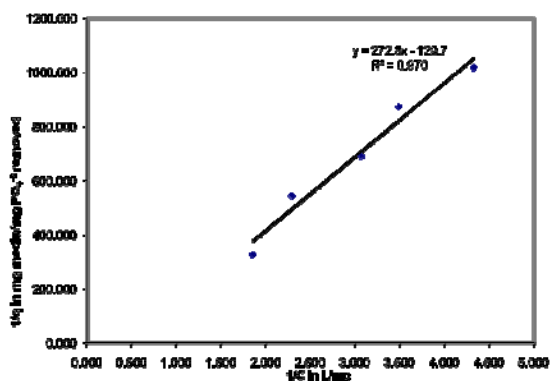
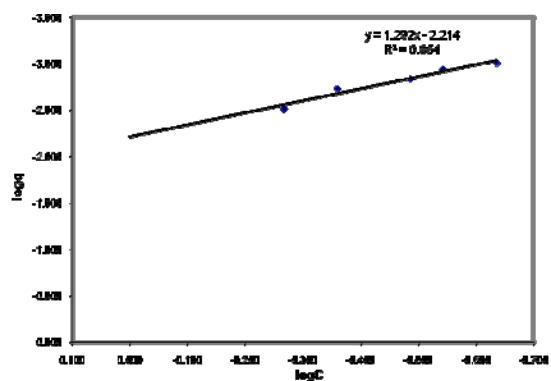

Figure 3 Figure showing the isotherm study for ammonia. (a) is Langmuir isotherm plot and (b) is Freundlich isotherm plot



(a)



(b)

Figure 4 Figure showing the isotherm study for orthophosphate. (a) is Langmuir isotherm plot and (b) is Freundlich isotherm plot

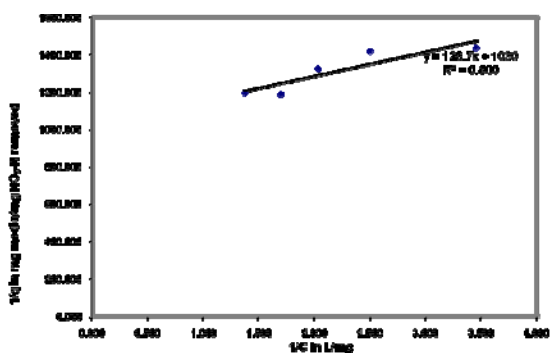

(a)

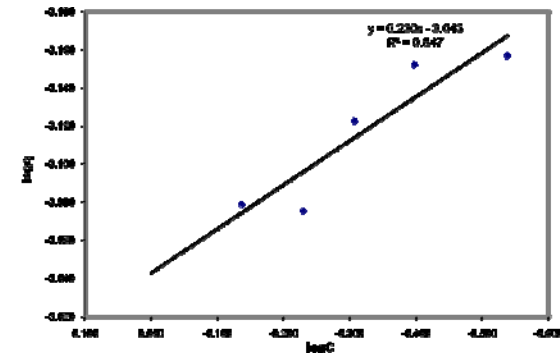

(b)

Figure 5 Figure showing the isotherm study for nitrate. (a) is Langmuir isotherm plot and (b) is Freundlich isotherm plot

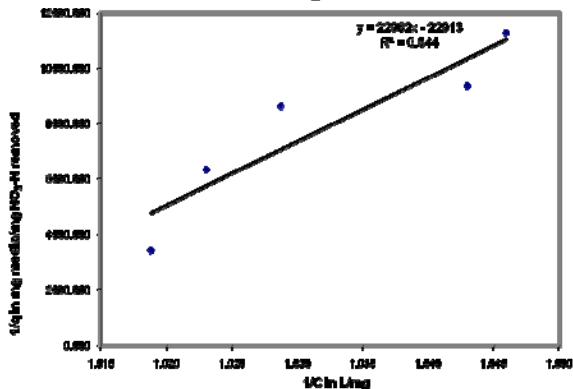

(a)

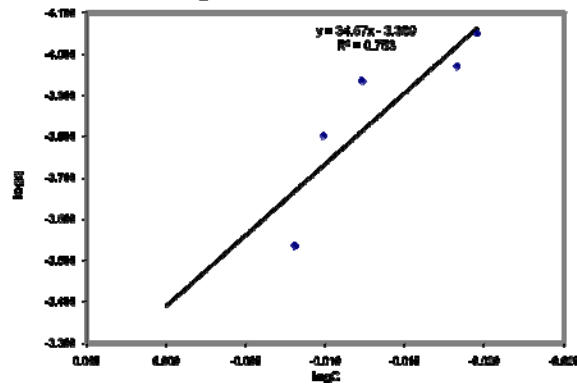

(b)

Figure 6 Figure showing the isotherm study for nitrite. (a) is Langmuir isotherm plot and (b) is Freundlich isotherm plot

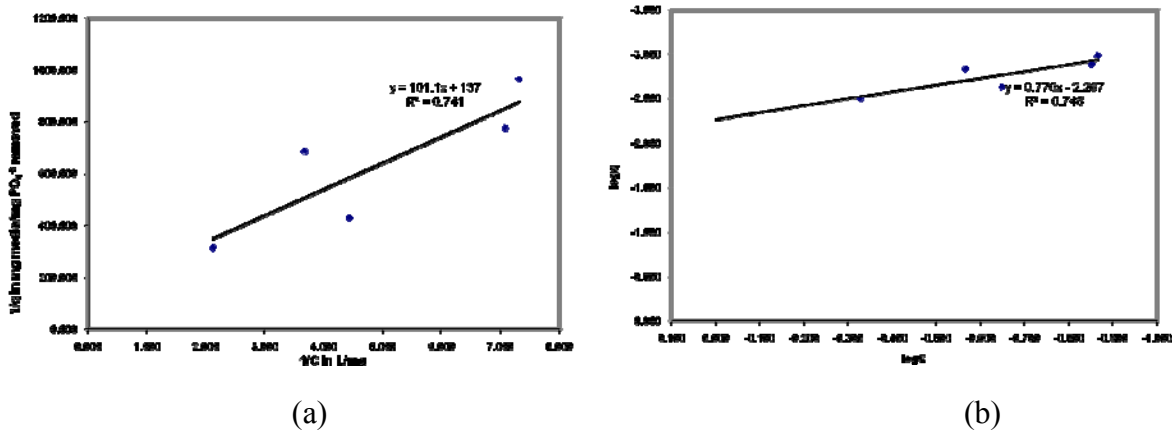

Figure 7 Figure showing the isotherm study for total dissolved phosphorus. (a) is Langmuir isotherm plot and (b) is Freundlich isotherm plot

Life Expectancy of the Media (does not include biological uptake)

For each 1,000 square foot watershed that has runoff of 48 inches per year (similar to an impervious area in Florida), stormwater volume per year is 29,920 gallons. Suppose that 1/3 cubic yard of sorption material (300,000 g) is specified at the bottom of a pond to remove OP in the runoff. This is 6 inches of media over 18 square feet of pond bottom. Ponds are usually 2-5 % of the impervious watershed or greater, or 20-50 square feet for this example. Based on our Langmuir isotherm test of OP, the maximum waste load is 0.008 mg OP/mg sorption media. So the maximum amount of OP that can be adsorbed by the sorption media is 2,310 g (0.008 mg/mg * 300,000 g). Assume that stormwater has an OP concentration of 0.5 mg/L on average, then the total amount of OP is about 56.6 g/year (i.e., $(29,920 * 3.785 * 0.5) / 1000$). As a result, the life expectancy of the sorption media mixture for OP removal would be about 40.8 years (2,310/56.6). This life expectancy may vary according to the type of sorption media used, the waste loads in stormwater, and the intensity, frequency and duration of the stormwater in the study area. Based on the same rationale, what are summarized in Table 7 present all the relevant life expectancies of the tested sorption media with respect to individual pollutant of concern. It appears that the effective removal of nitrogen species would lean to be more microbiological than physicochemical process as long as sufficient moisture is available.

Table 7 Life expectancy of sorption media mixture for different nutrient

Species	Life expectancy in years
Ammonia as Nitrogen	0.25
Orthophosphate	40.8
Nitrate as Nitrogen	2.11
Nitrite as Nitrogen	0.01
Total Dissolved Phosphorus	38.6

Removal Efficiency

A great difference of removal efficiency was observed for nitrogen and phosphorus species between the column test settings. Table 8 summarizes the information of removal efficiency. Findings in reaction kinetics analysis showed that if the influent concentration is lower (in the case of ammonia), the sorption media can remove ammonia in a relatively more efficient way. Our record showed that the removal efficiency may even reach a maximum with waste load concentration of 0.5 mg/L and 2.5 mg/L after 1 hour and 1.5 hours of hydraulic retention time (HRT), respectively. When the ammonia concentration was up to 5.0 mg/L, the removal efficiency was about 64% after 1.5 hours of HRT. Given that the ammonia concentration is normally not very high in stormwater, this sorption media mix should work well in terms of removing ammonia from stormwater runoff. The removal efficiency of nitrate was about 95.36%, 81.34% and 65.68% after 5 hours of HRT when the influent waste loads were 0.5 mg/L, 2.5 mg/L and 5.0 mg/L, respectively. The removal efficiency of nitrite was promising when its influent concentration was lower. Our record showed that the removal efficiency was about 94.14% and 98.72% when the influent waste loads were 0.5 mg/L and 2.5 mg/L, respectively. But it went down to 65.40% when the influent waste load was as high as 5 mg/L. With this observation, it can be concluded that sorption media is efficient and effective for the removal of both nitrate and nitrite at lower influent concentrations (i.e., 0.5 mg/L and 2.5 mg/L) that covers most of the cases in real world systems. Total nitrogen (TN) is the sum of all nitrogen species. From the above analysis, it is certain that the proposed sorption media can remove TN.

Phosphorus is expected to be removed by tire crumb, limestone and fine clay particles in the sorption media mixture. Orthophosphate is the main component of total

phosphorus (TP) and it is about 70% to 90% of TP. The removal efficiency of OP was 79.5%, 94.39% and 97.50% after 5 hours HRT when the influent concentrations were 0.5 mg/L, 2.5 mg/L and 5.0 mg/L, respectively. The removal efficiency of OP went up with increasing influent concentrations in the sense that the proposed sorption media may perform well if the stormwater has higher phosphorus concentration. The same tendency was observed for the cases of TDP and TP removal. The removal efficiency of TDP was 86.3%, 96.06%, and 98.165% when the influent concentrations were 0.5 mg/L, 2.5 mg/L, and 5.0 mg/L after 5 hours HRT. The removal efficiency of TP was above 99.0% no matter what influent concentrations occurred. Hence, it can be confirmed that the proposed sorption media should be effective in removing not only orthophosphate but also polyphosphate.

The removal efficiency of nutrients with the natural soil was also observed for the purpose of comparison. Findings confirmed that natural soil is not capable of removing nitrate in stormwater runoff. It could only remove 19.2% nitrate after 5 hours HRT if the influent concentration is 0.5 mg/L. Further, natural soil cannot adsorb and hold nitrate for a long time. After 3 hours HRT it starts to desorb or leach the nitrate. But natural soil seems to be quite effective in removing ammonia. The removal efficiency of ammonia was about 98.68% within 1.5 hours HRT when the influent concentration of 0.5 mg/L. The removal efficiency was about 96.20% within 1.5 hours HRT when the influent concentration was 5.0 mg/L. But natural soil cannot adsorb the ammonia for a long time and some desorption phenomenon was observed every time. Natural soil can adsorb some nitrite at lower influent concentration but it was not the case at higher influent concentration. The removal efficiency of OP by natural soil was not significant at lower influent concentration. Findings indicated that it can only remove 19.4% of OP at an influent concentration of 0.5 mg/L. But it may perform well in removing both TP and TDP. Both species had a removal efficiency of above 75% in our test.

The pH value of effluent varied between 7.0 to 8.0 from the sorption media columns and 6.0 to 7.5 in the natural soil column (i.e., the control case) at room temperature. The room temperature was between 22.0 °C to 24.0 °C. There is no reason to believe that pH will be a problem in the receiving water based on these tests.

Table 8 Summary of removal efficiency in column test

Species	HRT in hours	Initial Concentration in mg/L	Effluent concentration in mg/L	Removal efficiency in %
Ammonia	1.5	0.5	0	100
	1.5	2.5	0	100
	1.5	5	1.977	64.876
Nitrate	5	0.5	0.023	95.362
	5	2.5	0.476	81.347
	5	5	1.775	65.674
Nitrite	5	0.5	0.031	94.144
	5	2.5	0.032	98.726
	5	5	1.751	65.395
OP	5	0.5	0.117	79.51
	5	2.5	0.144	94.39
	5	5	0.124	97.506
TP	5	0.5	0.006	99.055
	5	2.5	0.013	99.464
	5	5	0.018	99.638
TDP	5	0.5	0.067	86.299
	5	2.5	0.097	96.068
	5	5	0.092	98.165

Kinetic Reactions

With the aid of the column test, it is now known that the proposed sorption media can uptake and remove the nutrient in about 5 hours from stormwater runoff whereas the natural soil can remove part of the nutrient if the HRT is long enough. HRT is critical for sorption media to achieve the necessary absorption/adsorption. Filtration kinetics of real filter media is currently modeled by applying a first-order kinetic model for some targeted constituents (Gomer et al., 2007). This is different with the biodegradation kinetics associated with microbial communities via nitrification and denitrification. In this study, a broader viewpoint was evaluated that the proposed sorption media in this research may follow either the first-order or the second-order filtration kinetics. The confirmation of this may provide us with a necessary link between the size of reactor and the possible removal efficiency. Therefore, graphs between $\ln(C_0/C)$ vs. time and $1/C$ vs. time for each species with different influent concentrations were plotted to verify this assumption. The equation, R-square value and rate constant may be determined from

these graphs. We found that it is very difficult to determine the kinetics for ammonia as it can be removed very quickly by the proposed sorption media. Overall, the OP follows the second-order reaction kinetics. In the case of OP testing, the second-order reaction kinetics may be derived with respect to a good R-square value of 0.70 to 0.94. The removal of OP by natural soil also confirmed that the same kinetics works well or as well as the other media. Also nitrate and nitrite also followed the second-order reaction kinetics. The R-square values of these two cases are 0.88 for nitrate and 0.81 for nitrite.

In Tables 9(a) and 9(b) the reaction kinetic analysis is summarized for the sorption media and natural soil. It can be concluded that all the species follow the second-order reaction kinetics more closely. This judgment was made based on the R-square values. Apparently, the proposed sorption media exhibits better removal efficiency in terms of all chemical species of concern (i.e. ammonia, nitrate, nitrite, total nitrogen, total phosphorus, total dissolved phosphorus and orthophosphate). Our justification is that ammonia, nitrate, nitrite, and total nitrogen were mainly removed by saw dust and tire crumb via adsorption whereas total phosphorus, total dissolved phosphorus and orthophosphate were mainly removed by tire crumb and limestone. However, phosphorus species may also be removed by other chemical reactions.

Finally, the chemical analysis for the abiotic test confirmed that the nutrient removal process in the natural state was mainly a physicochemical process. After 5 hours of hydraulic retention time, the removal efficiency of nitrate and OP was 83.32% and 92.20%, respectively with an initial concentration of 0.5 mg/L. The ammonia removal efficiency was about 100% after 1.5 hours of hydraulic retention time and the same initial concentration. All of the removal efficiencies remain about equal to what was observed in the kinetics analysis. Since the columns were not seeded with organisms or sludge added to the columns to foster any amenable microbial environment and the natural citrus grove sand was heated up to 105⁰C, it is believed that it is not possible for bacteria to grow in such a short hydraulic retention time in the media. In other word, no nitrification/denitrification process is triggered in our testing and the abiotic analysis proved the assumption (Hossain, 2008).

Table 9(a) Summary table of kinetics for the sorption media mixture

Species	Initial concentration in mg/L	first order equation	R ² for first order equation	K for first order equation (1/sec)	second order equation	R ² for second order equation	K for second order equation (L/mghr)
Nitrate	5	y=0.230x	0.653	0.749	y=0.074x+0.193	0.996	0.074
	2.5	y=0.330x	0.998	0.330	y=0.302x+0.391	0.920	0.302
	0.5	y=0.749x	0.265	0.249	y=9.516x+2.000	0.880	9.516
Ortho-Phosphate	5	y=0.521x	0.275	0.521	y=1.637x+0.201	0.859	1.637
	2.5	y=0.420x	0.114	0.420	y=1.511x+0.389	0.698	1.511
	0.5	y=0.105x	0.780	0.105	y=1.340x+1.754	0.940	1.34
Nitrite	5	y=0.222x	0.831	0.222	y=0.072x+0.198	0.919	0.072
	2.5	y=0.897x	0.990	0.897	y=5.088x+0.402	0.818	5.088
	0.5	y=0.683x	0.649	0.683	y=6.736x+1.879	0.929	6.736
TP	5	y=1.328x	0.781	1.328	y=11.275+0.202	0.961	11.275
	2.5	y=1.314x	0.523	1.314	y=19.46x+0.413	0.725	19.46
	0.5	y=0.954x	0.935	0.954	y=27.53x+1.68	0.751	27.53
TDP	5	y=0.942x	0.443	0.942	y=2.089x+0.199	0.912	2.089
	2.5	y=0.692x	0.738	0.692	y=1.715x+0.405	0.862	1.715
	0.5	y=0.519x	0.231	0.519	y=3.454x+2.045	0.358	3.454

Note: for first order $y=\ln(C_0/C)$ and $x=t$; for second order $y=1/C$ and $x=t$

Table 9(b) Summary table of kinetics for the natural soil (Hunter's Trace soil)

Species	Initial concentration in mg/L	First order Equation	R ² for first order equation	K for first order equation (1/sec)	Second order Equation	R ² for second order equation	K for second order equation (L/mghr)
Nitrate	5	y=0.230x	0.653	0.749	y=0.074x+0.1903	0.996	0.074
	0.5	y=0.066x	0.222	0.066	y=1.635x+2.146	0.213	1.635
Ortho-Phosphate	5	y=0.577x	0.388	0.577	y=0.443x+0.202	0.705	0.443
	0.5	y=0.036x	0.836	0.036	y=0.065x+1.650	0.820	0.065
Nitrite	5	y=0.146x	0.254	0.146	y=0.039x+0.197	0.305	0.039
	0.5	y=0.652x	0.881	0.652	y=6.101x+1.820	0.964	6.101
TP	5	y=1.003x	0.745	1.003	y=3.344x+0.221	0.912	2.090
	0.5	y=0.336x	0.846	0.336	y=1.425x+1.981	0.971	1.425
TDP	5	y=0.953x	0.412	0.953	y=1.946x+0.176	0.460	1.946
	0.5	y=0.620x	0.334	0.620	y=5.502x+2.083	0.663	5.502

Note: for first order $y=\ln(C_0/C)$ and $x=t$; for second order $y=1/C$ and $x=t$

APPLICATION POTENTIAL

Head Loss

The head loss, which reflects the permeability or percolation rate, is calculated based on the assumption of inter-event flow. Runoff is considered inter-event or not continuous as in a batch run. Stormwater retention ponds or dry ponds are areas that are normally dry, but function to infiltrate the water in the reservoirs during and after storm events. Within the natural soil column, the head loss was about 57.15 cm of water (22.5 inches of water) and in sorption media column the head loss was about 83.820 cm in water (34 inches of water). This is the head loss to allow the maximum infiltration capacity. The head loss information may be used to design the minimum depth of the retention pond so as the stormwater infiltrates at the design rate.

Engineering Feasibility Study

The engineering feasibility of dry ponds for nutrient removal should be considered in a relatively flexible way. Aerobic conditions in the batch testing showed the removal of phosphorus while anaerobic conditions in the column showed removal of nitrogen species. Without having functionally designed sorption media, typical removal rates for pollutants not discharged to surface waters in dry detention ponds are between 10%-20% (Urbonas and Stahre, 1993), while wet ponds may achieve up to 40% of nitrogen removal (Harper, 2007). Retention pond removal is a function of the size of the pond and the climatic zone, and typically 80% or more is achieved. But these efficiencies only address reduced surface water discharges and not what mass of pollutants enter the ground. However the rate of removal from discharges to both surface and ground waters can be increased with the use of sorption media that follow the recipes and the hydraulic retention times (HRT) noted in the previous results section and discussion. That media mix is referred to a functionally designed media. The thickness of sorption media layer at the bottom of the ponds required to achieve the target removal efficiency is related to the

HRT. From the kinetic column studies, this retention time is of the order of 5 hours. In an actual field condition, there may exist preferred path-ways in the media mix so that a prudent HRT should be specified that is greater than the laboratory column results. A design to hold the stormwater from double the laboratory time of 5 hours, or the use of 10 hours is not unreasonable. An engineered containment system can provide a control on retention time or a selection of media with infiltration rate limits can also achieve the same results.

The detention pond or wet pond is perhaps one of the most common types of stormwater treatment systems in Florida and the world. It provides a basin sized to hold a permanent pool of water while reducing peak flow runoff. The treatment of stormwater occurs during the inter-event storm period when long holding times allow for particle settling and biodegradation. One popular design is to utilize a sedimentation fore-bay that holds a percentage of the pond water and drains slowly through a standpipe into the main basin. When the fore bay capacity is reached, the contiguous storm events provide a fresh influx of stormwater which force some of the standing water out of the system and flow occurs over a weir into the permanent pool. However, many of the wet ponds might not have such a sedimentation forebay. The basic detention pond includes only the permanent pool which serves to remove pollution and attenuate peak flows by storing a specified volume of stormwater. Stormwater treatment with in-situ treatment units filled with sorption media can be used to treat stormwater that is being discharged normally from the pond. The captured water can also be withdrawn by a sump pump. The pump can be used to remove water near the bottom of the pond. Also the water in the pond can be re-circulated for treatment with improved water added to the pond at the upper layers. Figure 8 shows the layout of such a system in the wet ponds.

Another design is called a dry detention pond. Stormwater enters the pond and if not infiltrated, it is released. It operates until all the stormwater is either infiltrated or discharged. The effectiveness is typically less than the wet detention pond or a retention pond. Thus the effectiveness can be improved by treating the stored water with functional mix media. Thus, the design is similar to a wet pond, except the design pond storage is removed by a pump or gravity through the functional mixed media before the next runoff event.

Retention ponds are areas that are normally dry and function to hold the water for infiltration and evaporation during storm events. The design storage volume is calculated based on a specific target mass removal of runoff. They store a specific volume from a watershed and when a storm produces more than that volume, the runoff is bypassed from the pond. The removal efficiency of these ponds is based on the storage volume and the infiltration rates. They typically achieve higher reduction in the mass of pollutant discharge but groundwater protection is assumed to occur or there is minimum impact to the groundwater quality.

The sorption media can be contained by geotextile or plastic or clay and laid down at the bottom of the riprap apron area and encased in a sorption media jacket placed around a perforated riser (See Figure 9). There are many other designs that would permit the functional mix media to work. It should also be noted at this time that the assumed design volume of material should also be consistent with the lifetime of the media as was discussed earlier in this research report.

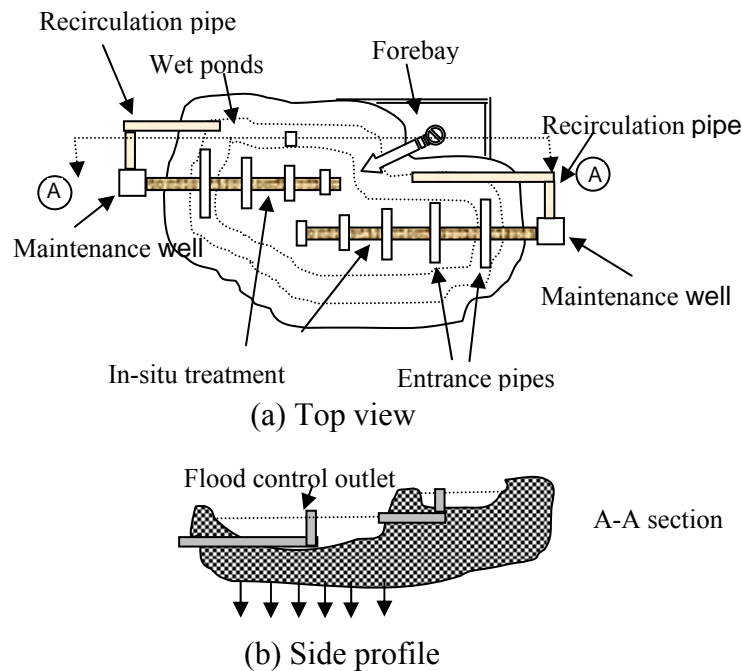

Figure 8 Wet pond with in-situ treatment units and low infiltration

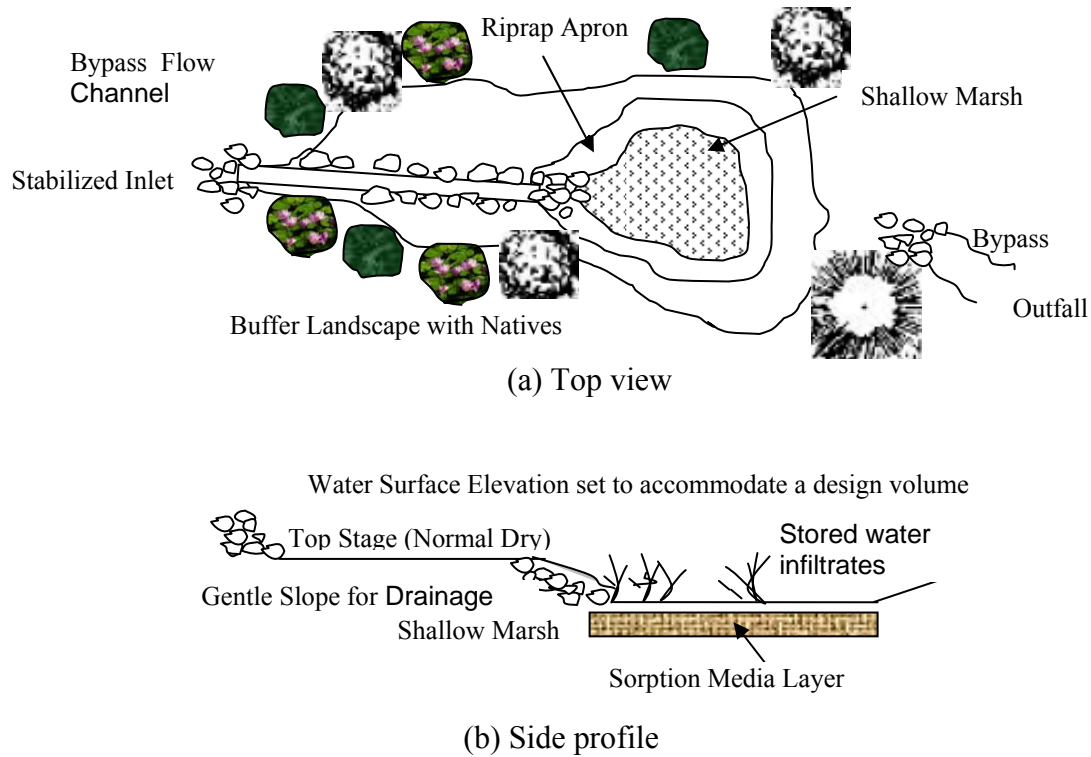

Figure 9 Retention pond with in-situ treatment

Cost and Benefit

The cost of the mixed media is about \$150 per cubic yard based on 2008 cost indices and at the point of supply. Travel or shipping cost plus placement and design costs are not included. Assuming that the final project cost is double the materials cost results in a capital cost of \$300 per cubic yard. One third of a yard was calculated in the life expectancy section of this report for 40 years of operation as needed for each 1,000 square feet of impervious watershed. Thus, the capital cost would be \$100 per 1,000 impervious square feet of watershed. For an acre of impervious area, the capital cost of media placement would be \$4,356 (100×43.56 thousand square feet in an acre). The cost of constructing a pond to store 3 inches of runoff (about 10,000 cubic feet) from an impervious acre is about \$20,000-\$30,000 (Brown and Schueler, 1997) adjusted to 2008 prices. A detention pond cost for 6 inches of runoff per impervious acre is assumed at \$35,000. When media is added to a detention pond, there is an additional cost for pumping and operation.

Using the above cost data, a comparison of currently designed ponds to ponds using functionalized sorption media is shown in Table 10. Land cost is not included and should not be because the pond with media is not larger in area relative to one without media. The comparisons also assume the design cost for the media is equal to the installation cost. Pond area is calculated as if the pond were designed to hold 3 inches of runoff from one impervious area. Also this cost comparison does not include the marginal cost of removing a unit pound of nutrients or the benefits incurred.

Table 10 Pond Cost Comparisons

<u>Pond Description</u>	<u>Cost Data per Impervious Acre</u>	
	<u>Capital</u>	<u>Operation (per year)</u>
Retention	\$20,000	\$800*
Retention with Media	\$28,712	\$800*
Detention/Flood Control	\$35,000	\$800*
Detention /Flood with Media	\$46,000	\$1000**

*Assumes four times per year maintenance and site visit

** Assumes electrical pumping cost as the differential

Assuming the pond removal effectiveness is 50% for any pollutant, the capital cost ratio to % removal benefit for the pond is \$400 per % removal (\$20,000/50%) or \$10.00/% removal/year (based on a 40 year life expectancy). The functional media mix would remove most of the remaining 50% at a cost benefit of \$2.18/% removal/year (4356/(40yr)x(50%)). Thus the benefit per capital cost investment is lower (\$2.18 vs. \$10.00) with functionalized media relative to that obtained when constructing a pond with the same assumed removal.

The operating cost of a retention pond is assumed to be minimal. Also, the cost of operating and maintaining the functionalized mixed media is minimal or zero if it is placed in the bottom of a pond. However, for a wet detention pond the operating cost for the functionalized media would involve electrical cost if a pump were used.

Another cost to benefit comparison can be made based on TP mass removal using recent Florida stormwater construction projects. The State Department of Environmental

Protection (Livingston, 2008) keeps records of stormwater construction projects for a variety of methods (alum injection, wet ponds, retention ponds swales, and separators). Their records indicate an average capital cost to remove one pound of phosphorus per year per acre of watershed (not all impervious) to be about \$150. Ninety percent (90%) of the time the cost of removal is less than \$303 per pound of phosphorus per year per acre. The average percent impervious for all projects is assumed at 20%, thus the construction cost per impervious acre per pound of TP removed per year is on the average about \$750 per impervious acre and 90% of the time the cost is less than \$1515. Using the assumption of 0.5 mg/l TP, 4 feet of runoff, and one acre of impervious area, the TP from an impervious acre per year is 5.44 pounds ($0.5 \times (3.79\text{L/gal}) \times (43,560\text{sq ft}) \times 4 \text{ feet of runoff} \times 7.48\text{gal/CF}/(1000 \times 454 \text{ g/lb})$). The construction cost per impervious acre per pound of TP removed per year is calculated as \$800 ($4356/5.44$). Thus when compared using construction cost to current Florida stormwater management projects of all types the functionalized sorption media cost is approximately equal to the average (\$800 vs. \$750).

It should be obvious that costs vary widely. For each pond location, the cost and benefit may have to be calculated; however it should be apparent that the marginal cost of construction per percent removal (benefit) decreases when the mixed media is used relative to the initial pond construction cost. Also the average capital cost of current stormwater projects per % removal is about equal to those of the functionalized media.

CONCLUSIONS

One result of this research is the specification of a recipe for sorption media mix. The media mix is a combination of sandy loam material, limestone, tire crumb and sawdust. There are other media mixes readily available in Florida that may also be used, however with the specified mix, removal efficiencies and kinetics have been determined. As an example, Moberg (2008) eliminated limestone from the media mix and showed overall removals in bath and column testing to be equal to the results reported within this work. The methodologies of this research should be followed for other testing. The testing conditions were done in columns and batch modes to simulate the practical or functional application of the media mix. Thus the resulting media mix can be called a functionalized media mix.

The results of batch and column tests indicated that the functionalized media mix has the potential to effectively and efficiently remove most of the nutrient species within an appropriate detention time via the sorption processes. The life expectancy of the proposed sorption media is reasonably long in terms of orthophosphate removal. Using half the volume of media will reduce the life expectancy by half. For an example unit size impervious watershed, the life time was calculated as 40 years for a specific volume of material and based on chemical reactions. When biological removals are considered, the life time of the mixed media should increase.

The removal of the nitrate ion (NO_3^-) is minimal in soils that are negatively charged so the NO_3^- ion is not bound to the soil. Therefore, nitrate ions move freely with the soil solution and are readily leachable. Nitrogen, particularly nitrate, easily moves from terrestrial ecosystems into surface and groundwater, including lakes, streams, rivers, and estuaries. The removal of nitrates will rely on the microbes, such as ammonia oxidizing bacteria (AOB), nitrogen oxidizing bacteria (NOB) and denitrifiers. Microbe identification is out of the scope of this research. However, removal under saturated and anaerobic laboratory column conditions is possible and was demonstrated. A HRT of 5 hours was considered sufficient to remove nitrate under anaerobic conditions. Design implications for depth and holding times are possible with this data.

The column test was set up in a manner that may prove its functionality for application in retention ponds where stormwater impact is in a batch mode. Furthermore, the design of wet ponds may follow the same philosophy. The assurance of HRT would be a major challenge in applying this concept because the time for the intermittent flow (i.e., infiltrate) to pass through the sorption media layer constitutes the legitimate HRT. However, both wet and dry ponds in real world systems may count on microbiological effects to remove nitrogen as well, and thus the contribution from adsorption and absorption would not dictate the ultimate removal efficiency. The ultimate removal effectiveness with biological activity is most likely significant. This is especially true in the wet ponds.

Sorption media are not expensive or in the order of less than \$150 per cubic yard of material at the point of mixing at 2008 market conditions. Thus such systems for removing nutrients should be cost effective. There is little maintenance cost associated with the functional media mix. Based on capital cost, the additional removal obtained before either discharge from a wet pond or infiltration from a retention pond is less than the per unit removal cost associated with construction of the pond.

Future research should also be done with other sorption media mixes for both stormwater and wastewater treatment. The research may also focus on the detection of microbiological activities, such as AOB, NOB, and denitrifiers, to ensure the denitrification process using real-time PCR instrumentation. In case of practical application the retention time is a most important issue that needs to be considered but it may be difficult to ensure on-site. Construction methods to achieve an HRT however are possible. There is also a need to develop the design-based simulation model that may aid in the illumination of the system configuration and assess the effectiveness of nutrient control for the real world facilities.

LIST OF REFERENCES

- Analytical & Environmental Consultants (AEC) (2005), locally available adsorbing materials, sediment sealing, and flocculants for chemical remediation of lake and stream water,
<http://www.ebop.govt.nz/media/pdf/report/Chemicalremediationstudy.pdf>,
accessed in June, 2007.
- ASTM (D854-92), Standard test method for specific gravity of soils, ASTM international.
- ASTM (D2434-68), Standard test method for permeability of granular soils (Constant head), ASTM international.
- ASTM (D421-85), standard practice for dry preparation of soil samples for particle size analysis and determination of soil constants, ASTM international.
- Baeseman, J. L., Smith, R. L., and Silverstein, J. (2006), Denitrification potential in stream sediments impacted by acid mine drainage: effects of pH, various electron donors and iron, *Microbial Ecology*, 51(2), 232-241.
- Baker, L. A. (1992). Introduction to nonpoint source pollution in the United States and prospects for wetland use. *Ecological Engineering*, 1, 1-26.
- Bell, W., Stokes, L., Gavan, L. J., and Nguyen, T. N. (1995), Assessment of the pollutant removal efficiency of Delaware Sand filter BMPs, *City of Alexandria, Department of Transportation and Environmental Services*, Alexandria, VA.
- Benson, C. H. (2001), Using waste foundry sands as reactive media in permeable reactive barriers, DNR project #147.
- Boving, T.B. and Zhang, W. (2004), Removal of aqueous-phase polynuclear aromatic hydrocarbons using aspen wood fibers, *Chemosphere*, 54, 831-839.
- Blrkholz, D. A., Belton, K. L. and Guldottl, T. L. (2003). Toxicological evaluation for the hazard assessment for tire crumb use in public playground, *Journal of the Air and Waste Management Association*, 53, 903-907.
- Birch, G. F., Fazeli, M. S., and Matthai, C. (2005). Efficiency of an infiltration basin in removing contaminants from urban stormwater. *Environmental Monitoring and Assessment*, 101, 23-38.

- Braun-Howland, E. (2003), Validity assessment of methods to distinguish between ruminant and human sources of fecal contamination in watersheds, *New York State Water Resources Institute Annual Technical Report-FY 2003*, Cornell University, Ithaca, NY.
- Brown, W., and Schueler, T. (1997), The Economics of Stormwater BMPs in the Mid-Atlantic Region: Final Report, Center for Watershed Protection, Maryland.
- Clark, S., and Pitt, R. (1999), Stormwater treatment at critical areas: Evaluation of filter media, EPA 600/R-00/010, Washington D. C., USA.
- Clark, S., Pitt, R., and Brown, D., (2001), Effect of anaerobiosis on filter media pollutant retention, *Presented at the Engineering Foundation and the American Society of Civil Engineers Conference on Information & monitoring needs for evaluating the mitigation effects of BMPs*, Snowmass, CO.
- Chang, N. B., Wanielista, M., and Hossain, F., (2008). "Material Characterization and Kinetics Study of Green Sorption Media for Nutrient Removal in Stormwater Management Facilities," World Environmental and Water Resources Congress, ASCE/EWRI-2008 Conference, May 13-16, 2008, Honolulu, Hawaii, oral presentation.
- Crittenden, J. C., Trussell, R. R., Hand, D. W. (2005). Water treatment: principles and design, 2nd edition, John Wiley & Sons inc., USA.
- Darbi, A., Viraraghavan, T., Butler, R., and Corkal, D. (2002). Batch studies on nitrate removal from potable water, *Water South Africa*, 28(3), 319-322.
- DeBusk, T. A., Langston, M. A., Schwegler, B. R., and Davidson, S. (1997). An evaluation of filter media for treating stormwater runoff, *Proceedings of the fifth Biennial Stormwater Research Conference*, 82-89.
- Forbes, M. G., Dickson, K. L., Saleh, F., Doyle, R. D., Hudak, P., and Waller, W. T., (2005), Recovery and fractionation of phosphate retained by lightweight expanded shale and masonry sand used as media in subsurface flow treatment wetlands, *Environmental Science & Technology*, 39(12), 4621-4627.
- Gabel, B., Kozicki, R., Lahl, U., Podbielski, A., Stachel, B., and Struss, S. (1982). Pollution of drinking water with nitrate, *Chemosphere*, 11, 1147-1154.

- Gálvez, J. M., Gómez, M. A., Hontoria, E., and López, J. G. (2003). Influence of hydraulic loading and air flow rate on urban wastewater nitrogen removal with a submerged fixed-film reactor, *Journal of Hazardous Materials*, B101, 219-229.
- Gan, Q., Allen, S. J., and Matthews, R. (2004). Activation of waste MDF sawdust charcoal and its reactive dye adsorption characteristics, *Waste Management*, 24, 841-848.
- Gisvold, B., Ødegaard, H., and Føllesdal, M. (2000). Enhanced removal of ammonium by combined nitrification/ adsorption in expanded clay aggregate filters, *Water Science and Technology*, 41(4-5), 409-416.
- Graves, G. A., Strom, D. G., and Robson, B. E. (1998). Stormwater impact to the fresh water Savannas Preserve marsh, Florida, Department of Environment protection and St. Johns River Water Management District, Florida, USA.
- German, E. R. (1989). Quantity and quality of stormwater runoff recharged to the Floridan Aquifer system through two drainage wells in the Orlando, Florida area. US Geological Survey – Water Supply paper 2344. Prepared in cooperation with the Florida Department of Environmental Regulation. Denver, CO.
- Görner, H., Engh, T. A., Syvertsen, M., and Zhang, L. (2007). Removal of Na and Ca from aluminum scrap through filtration, *Materials Science Forum*, 546-549, 801-806.
- Güngör, K. and Ünlü, K. (2005). Nitrite and nitrate removal efficiencies of soil aquifer treatment columns, *Turkish J. Eng. Env. Sci.*, 29, 159-170.
- Harper, H.H., (2007). Evaluation of Current Design Criteria within the State of Florida. Department of Environmental Protection, Tallahassee, Florida.
- Harris, W. G., Rhue, R. D., Kidder, G., Brown, R. B., and Littell, R. (1996). Phosphorus retention as related to morphology of sandy coastal plain soil materials, *Soil Science Society of American Journal*, 60(5), 1513-1521.
- Han, D. W., Yun, H. J., and Kim D. J. (2001). Autotrophic nitrification and denitrification characteristics of an up flow biological aerated filter, *Journal of Chemical Technology and Biotechnology*, 76, 1112-1116.

- Hedström, A. (2006). Reactive filter materials for ammonium and phosphorus sorption in small scale wastewater treatment, Doctoral Dissertation, Luleå University of Technology, IAAAN: 1402-1544.
- Hossain, F. (2008). Nutrient Removal from Stormwater By Using Green Sorption Media, Master's Thesis, University of Central Florida.
- Hsieh, C. H. and Davis, A. P. (2003). Multiple-event study of bioretention for treatment of urban stormwater runoff, Diffuse Pollution Conference Dublin, Ireland.
- Hsieh, C. H. and Davis, A. P. (2005). Evaluation and optimization of bioretention media for treatment of urban stormwater runoff, *Journal of Environmental Engineering (ASCE)*, 131(11), 1521-1531.
- Huang, C. P., Wang, H. W., and Chiu, P.C. (1998). Nitrate reduction by metallic iron, *Water Research*, 32(8), 2257-2264.
- Jokela, C. H. Y., Kettunen, R.H., Sormunen, K. M., and Rintala, J. A. (2002). Biological nitrogen removal from municipal landfill leachate: low-cost nitrification in biofilters and laboratory scale in-site denitrification, *Water Research*, 36, 4079-4087.
- Kahl, J. S., Norton, S. A., Fernandez, I. J., Nadelhoffer, K. J., Driscoll, C. T., and Aber, J. D. (1993). Experimental inducement of nitrogen saturation at the watershed scale. *Environmental Science and Technology*, 27, 565-568.
- Kietlińska, A., and Renman G. (2005). An evaluation of reactive filter media for treating landfill leachate, *Chemosphere*, 61, 933-940.
- Kim, H., Seagren, E. A., and Davis A. P. (2000) Engineering Bioretention for Removal of Nitrate from Stormwater Runoff, in WEFTEC 2000 Conference Proceedings on CDROM Research Symposium, Nitrogen Removal, Session 19, Anaheim CA, Oct. 2000.
- Korkusuz, E. A., Beklioglu, M., and Demirer, G. N. (2007). Use of blast furnace granulated slag as a substrate in vertical flow reed beds: field application, *Bioresource Technology*, 98, 2089-2101.
- Lazaridis, N. K. (2003). Sorption removal of anions and cations in single batch systems by uncalcined and calcined Mg-Al-Co₃ hydrocalcite, *Water, Air and Soil Pollution*, 146, 127-139.

- Li, Z. (2003). Use of surfactant-modified zeolite as fertilizer carriers to control nitrate release, *Micro porous and Mesoporous Materials*, 61(1), 181-188.
- Lisi, R. D., Park, J. K., and Stier, J. C. (2004). Mitigation nutrient leaching with a sub-surface drainage layer of granulated tires, *Waste Management*, 24, 831-839.
- Livingston, E., (2008). TMDL Project list construction cost and removal data, FDEP file records, Tallahassee, Florida, June.
- Moberg, M., (2008). The Effectiveness of Specifically Designed Filter Media to Reduce Nitrate and Orthophosphate in Stormwater Runoff, MS Thesis, UCF, Orlando.
- Mothersill, C. L., Anderson, B. C., Watt, W. E., and Marsalek, J. (2000). Biological filtration of stormwater: field operations and maintenance experiences. *Water Quality Research Journal Canada*, 35(3), 541-562.
- Namasivayam, C., Sakoda, A., and Suzuki, M. (2005). Removal of phosphate by adsorption onto oyster shell powder-kinetic studies, *Journal of Chemical Technology and Biotechnology*, 80, 356-358.
- Peterjohn, W. T., Adams, M. B., and Gilliam, F. S. (1996). Symptoms of nitrogen saturation in two central Appalachian hardwood forest ecosystems. *Biogeochemistry*, 35, 507-522.
- Phelps, G. G. (2004). Chemistry of ground water in the Silver Springs basin, Florida, with emphasis on nitrate: U.S. Geological Survey Scientific Investigations Report 2006-1107, 51 p.
- Phelps, G. G., Walsh, S. J., Gerwig, R.M., and Tate, W. B. (2006). Characterization of the Hydrology, Water Chemistry, and Aquatic Communities of Selected Springs in the St. Johns River Water Management District, Florida, 2004: U.S. Geological Survey Scientific Investigations Report 2004-5144, 54 p.
- Ray, A. B., Selvakumar, A., and Tafuri, A. N. (2006). Removal of selected pollutants from aqueous media by hardwood mulch, *Journal of Hazardous Materials*, B136, 213-218.
- Richman, M. (1997). Compost media capture pollutants from stormwater runoff, *Water Environment & Technology*, 9, 21-22.
- Rebco II (2007). www.perlite.net, accessed in June, 2007.

- Rocca, C.D., Belgiorno, V., and Meric, S. (2005). Cotton-supported heterotrophic denitrification of nitrate-rich drinking water with a sand filtration post-treatment, *Water South Africa*, 31(2), 229-236.
- Savage A. J. and Tyrrel, S. F. (2005). Compost liquor bioremediation using waste materials as biofiltration media, *Bioresource Technology*, 96, 557-564.
- Sawyer, C. N., McCarty, P. L. and Parkin, G. F. (2003). Chemistry for environmental engineering and science, 5th edition, *McGraw Hill Publishing*, New York, pp-663.
- Schipper, L. A., Barkle, G. F. and Vukovic, M. V. (2005). Maximum rates of nitrate removal in a denitrification wall, *Journal of Environmental Quality*, 1270-1276.
- Seelsaen, N., McLaughlan, R., Moore, S., Ball, J., and Stuetz, R. (2006). Pollutants removal efficiency of alternative filtration media in stormwater treatment, *Water Science & Technology*, 54(6-7), 299-305.
- Sengupta, S. and Ergas, S. J. (2006). Autotrophic biological denitrification with elemental sulfur or hydrogen for complete removal of nitrate-nitrogen from a septic system wastewater, *a report submitted to The NOAA/UNH cooperative institute for costal and estuarine environmental technology (CICEET)*.
- Shin, H. S., Yoo, K. S. and Park, J. K. (1999). Removal of polychlorinated phenols in sequential anaerobic-aerobic biofilm reactors packed with tire chips, *Water Environment Research*, 71(3), 363-367.
- St. Johns River Water Management District (SJRWMD) (2008). Springs of the St. Johns River Water Management District, [cited March 2008] <http://www.sjrwmd.com/springs/index.html>
- Tshabalala, M. A. (2002). Use of Lignocelluloses materials as sorbents for pesticide and phosphate residues, *USDA Forest Division, Madison, WI* 53705-2398.
- Tesoriero, A. J., Liebscher, H., and Cox, S. E. (2000). Mechanism and rate of denitrification in an agricultural water sheds: electron and mass balance along groundwater flow paths, *Water Resources Research*, 36(6), 1545-1559.
- Urbanas, B. and Stahre, P. (1993). *Stormwater: Best Management Practices and Detentions for Water Quality, Drainage, and CSO Management*. Prentice Hall, Englewood Cliffs, NJ.

- United States Environmental Protection Agency (USEPA) (1988), Design manual-constructed wetlands and aquatic plant systems for municipal wastewater treatment, EPA/525/1-88/022, US Environmental Protection Agency, Center for Environmental Research Information, Cincinnati, OH, USA.
- United States Environmental Protection Agency (USEPA) (1993). Nitrogen control manual, EPA-625/R-93-010, Office of Research and Development, U.S. Environmental Protection Agency, Washington, D.C., USA.
- United States Environmental Protection Agency (USEPA) (1999). Stormwater Treatment at Critical Areas Evaluation of Filtration Media. EPA 600/R-00/010, Office of Research and Development, U.S. Environmental Protection Agency, Washington, D.C., USA.
- Urbonas, B. and Stahre, P. (1993). *Stormwater: Best Management Practices and Detentions for Water Quality, Drainage, and CSO Management*. Prentice Hall, Englewood Cliffs, NJ, USA.
- Volokita, M., Belkin, S., Abeliovich, A., and Soares, M. I. M., (1996), Biological denitrification of drinking water using newspaper, *Water Res.*, 30(4), 965-971.
- Vitousek, P. M., Aber, J., Howarth, R. W., Likens, G. E., Matson, P. A., Schindler, D. W., Schlesinger, W. H., and Tilman, G. D. (1997). Human alteration of the global nitrogen cycle: causes and consequences. *Ecology*, 1, 1-16.
- Water Environment Federation; American Society of Civil Engineers; Environmental and Water Resource Institution (WEF, 2005), Biological nutrient removal (BNR) operation in wastewater treatment plants, Manual of practice no. 30, WEF press and McGraw Hill, USA.
- Wanielista, M. (2008). Feasibility Study of Waste Tire Use in Pollution Control for Stormwater Management and Water Conservation in Florida. Final Report, University of Central Florida, August 2008.
- Zhang, T. C. (2002). Nitrate removal in sulfur: limestone pond reactor, *Journal of Environmental Engineering, ASCE*, 128(1), 73-84.